

XXIII. *Description of an improved Air-Pump, and the Account of some Experiments made with it.* By Mr. Tiberius Cavallo, F. R. S.

Read July 3, 1783.

THE principal improvements which the air-pump received since it was first invented, were contrived by Mr. SMEATON, F. R. S. and are described in the XLVIIth volume of the Philosophical Transactions. This ingenious gentleman, considering the imperfections of the air-pumps usually made, not only found means to correct several of them, but improved almost every part of the machine, so as to render it incomparably superior to any thing of the kind done before.

It appears, by some accurate experiments of Mr. NAIRNE, F. R. S. described in the LXVIIth volume of the Phil. Transf. which were made with an air-pump constructed after Mr. SMEATON'S principle, that by means of the best air-pumps made before Mr. SMEATON'S invention, the rarefaction of the air within the receiver could never have been brought to more than forty or fifty times, if the heat of the place was about 57° ; that even with Mr. SMEATON'S pump the receiver could not be exhausted beyond 70° or 80° of rarefaction, when moist leathers were used, or moisture was in any way introduced within the receiver; but that when this pump is quite free from moisture, and is newly cleaned, oiled, and put together, then.

then the air may by it be rarefied about 600 times, and not farther*.

The principal cause which prevents this pump to exhaust farther than that limit is the weakened elasticity of the air remaining within the receiver, which, decreasing in proportion as the quantity of the air within the receiver is diminished, becomes at last incapable of lifting up the valve, which opens the communication between the receiver and the barrel; consequently no more air can in that case pass from the former to the latter.

To remove this principal imperfection of the best air-pumps had been attempted by several ingenious persons; but, as far as I know, was never obtained before the happy contrivance of the air-pump, which I am going to describe in the following pages.

Being in want of a good air-pump, and imagining that the opening and shutting the communication between the barrel and the receiver might, instead of the valve, be performed by means of a stop-cock, particularly constructed upon an idea of mine; I communicated my plan, about the latter end of the last year, to Mr. JACOB BARNARD HAAS, an ingenious workman in the philosophical-instrument way, who, in partnership with Mr. JOHN HENRY HURTER, had lately established a manufactory of philosophical instruments. Mr. HAAS remarked, that according to my plan the friction of the parts of

* The degree of rarefaction shewed by what is called the pear-gage, when any vapour of water is within the receiver, is not to be considered as the degree of rarefaction of the elastic fluid in the receiver, but only of the air; for though the air may be exhausted, yet the vapour of water will supply its place; we shall, therefore, only take notice of the exhaustion when no vapour or moisture is within the receiver. See NAIRNE'S Experiments, Phil. Trans, vol, LXVII.

the machine would be too great, and therefore the pump, if it answered at all, was not likely to be durable. In consequence of this, he considered upon some plan or other which might answer the same purpose in a better way, and soon hit upon a method of lifting up the valve at the bottom of the barrel, and of shutting it again at pleasure; which method being put into execution, has been found to answer exceedingly well.

Besides this capital improvement, his air-pump is rendered altogether more convenient for philosophical experiments, by answering several purposes, which will be enumerated after its description.

Plate I. shews a perspective view of this pump. Plate II. exhibits a geometrical delineation of its metal or working parts detached from the wooden frame. And plate III. represents a section of its parts. The letters of reference are made to answer to the same parts in all the plates.

In plate III. fig. 1. AABI is the barrel of the pump, to the broad or flat ends of which are screwed, by means of five screws, the pieces CE and K, with leathers between, to render the junctures perfectly air-tight*. The upper piece CE contains the collar of leathers for the handle or axis GG of the piston to go through, and the basin F, which serves for a cap to screw down the leathers, at the same time that it holds the oil, which may be put into it, in order to let the collar of leathers hold very tight; though it is shewn, by experience, that when the leathers are perfectly soaked, there is not the least occasion to keep any oil in the basin F. The same upper piece

* All the leathers used for this pump are soaked in melted hog's lard; and when the parts of the instrument are put together, a little oil is smeared upon those surfaces of the brass pieces which go against the leather, though this oil may be spared.

CE contains the valve at E, which lets the air pass upwards, but prevents its return, and which is so contrived as that, when the piston is drawn quite to the top of the barrel, the least possible quantity of air should be left into the barrel. The parts which form this valve are shewn separately in fig. 3. where 1,3 is a brass piece that screws into a proper cavity made for its reception in the piece CE, and which is hollow, except its lower part, where it consists of a thin lamina perforated with a small hole 3. Into the hollow of the last mentioned part is screwed the other perforated piece 2,4, having a slip of oil-silk stretched over its lower part 4, and tied round a small indenture or groove made on its lower part. This slip of oil-silk answers better than a piece of bladder or leather: it just covers the hole 3, and is about four times broader than the diameter of the hole.

It will be easily conceived, that when the air is forced through the hole 3, it will lift up the slip of oil-silk, and passing by the sides of it, and also through the large perforation of the piece 2,4, will go upwards, &c.; but can by no means return backwards, since any pressure, that the air makes on the upper part of the oil silk, will only stop the passage more effectually.

A valve much like this is in the piston, the parts of which are shewn separately in fig. 4. *u* is a perforated brass piece screwed to the cylindrical handle or axis GG, which is also perforated with a short and bent hole. The piece *x* is screwed into the part *u*, and contains a valve, *viz.* a small piece 6 with a slip of oil-silk tied round its groove *yy*, which slip of oil-silk bears against the hole 5. The piece *x* screwing into the other piece *u*, fastens the round leathers which, about thirty in number, form the stopping part of the piston, and rub with their edges against the cavity of the barrel. This is a very useful improvement,

ment, since the common way of using two leathers turned over corks is both troublesome to make, and seldom fits exactly.

The piece K fastened to the lower end of the barrel is perforated with a hole, the direction of which is clearly seen in the figure, and which communicates with the perforation of the round piece L, which is screwed to K with a leather between. The perforation therefore of K communicates with the cavity of the brass tube RS, this being soldered to L. The part of the piece K, which projects within the barrel, is smaller in diameter than the cavity of the barrel, and the intervening space is exactly fitted by the moveable ring 8, 8, the two parts of which are screwed together, holding fast between, the edge of a piece of oil-silk, which stretches over the upper part of the piece K, and covers its aperture. A vertical view of the above-mentioned oil-silk, with five holes in it, is shewn in fig. 6.

It appears from this description, that the air can pass through the valve from without to within the barrel, but not *vice versa*. It will be also easily conceived, that the air can pass from the cavity of the tube R through the perforation of the pieces L and K, within the cavity of the barrel, only when the said air has elasticity, or force enough to push up the oil-silk. Now the principal improvement in this machine is, to lift up the oil-silk by a power applied externally, when the weakened elasticity of the air within the cavity of the tube R, &c. is not capable of doing it by itself, and here follows the description of this mechanism.

The double ring 8, 8, which holds the oil-silk, is fastened to two steel wires 9, 9, which are shewn in fig. 5.; this figure being a section of the lower part of the pump through a plane perpendicular to the plane of the section, fig. 1. Those wires

pass through collars of leathers held in proper brass boxes HQ, screwed to the piece K, and furnished with caps, 11, 11. The lower extremities of the wires are fastened to the cross bar, 7, 7, of the brass frame, OOO, a vertical view of which is shewn in fig. 4. of plate II.

From the middle of the piece L, fig. 1. pl. III. a pillar M proceeds, the lower part of which, branching into two horizontally, forms an axis z, z , fig. 4. pl. II. about which the brass frame OOO moves a little way upwards and downwards.

It appears from this description, that if the frame OOO fig. 4. pl. III. is moved upwards, the wires 9, 9, and likewise the double ring 8, 8, with the oil-filk, being all connected together, will be pushed also upwards; consequently, the oil-filk being removed from the hole of the piece K, a free communication is opened between the cavity of the tube R, and the cavity of the barrel, through which the air, however rarefied or weakened in elasticity, can pass without the least impediment.

In order to move the brass frame upwards, the end of a lever P bears against it. This lever is shewn in fig. 3. of plate II. which is a front view of part of the pump, whereas fig. 1. of the same plate is a side view of it. The center of motion of the lever is at 13, that is, between two side prominences of the piece 12, 12, which is fastened by screws to one of the wooden pillars of the frame of the machine. The part 15 of the lever, which projects beyond the wooden pillar, is made with a joint, by which means it may be turned upwards, as represented by 17, for packing it more conveniently.

When the valve is to be opened, the foot of the operator must press upon the extremity 15 of the lever, by which means the other extremity P, the frame OOO, the wires 9, 9, and the double ring 8, 8, with the oil-filk, are all lifted up. But in
order

order to bring down again all those parts, and to shut the valve when the pressure of the foot is removed, there is an open brass tube N, fastened to the piece K, which contains a spiral spring, that, bearing against the extremity of the brass frame OO, pushes it downwards.

This principal mechanism being dispatched, it will be very easy to describe the remaining parts of this excellent machine: but before we proceed to that, I shall briefly describe another mechanism, which Mr. HAAS has lately contrived, to supply the place of that just mentioned, *viz.* of the lower part of the instrument, as being much more simple, and capable of answering the same purpose.

A section of this new thought, which he is going to execute for another pump, is shewn in fig. 7. of plate III.

AB is the lower extremity of the barrel. CCDE is a piece of brass perforated quite through with a large and cylindrical hole, and is screwed to the barrel instead of the piece K of fig. 1. with a leather between. On one side of this piece CDE, part of the surface is flattened, and to it is adapted, by means of screws and a leather, the piece of brass G, to which the tube H is soldered, which corresponds to the tube RS of fig. 1. The aperture of CC, towards the cavity of the barrel, is covered by a piece of oil-silk, like that represented in fig. 6, which is kept stretched by a brass ring LL, sunk into the piece CCD.

Within the cylindrical perforation of the piece CCDE, there is a long piston KI*r*, consisting of the following parts. IK is its axis, which spreads at top into a flat plate *r*, and the lower extremity of which is fastened at N to the lever MO, which moves round the center M. Towards the middle of the axis, there is a piece of brass, the shape of which is more easily

understood by inspecting the figure, than by a verbal description, which piece confines the round leathers from itself to the plate *r*, and also from itself to the other plate, which is screwed upon the axis at *K*.

Between the last mentioned plate and the cap *F*, there is a spiral steel spring, which always pushes the piston upwards. Lastly, the axis of the piston is perforated from its top till towards the middle, where the perforation, opening side-way, communicates with the cavity of the tube *H*.

Now, when the piston is pushed upwards, as it always is when the extremity *O* of the lever is not pressed down, then the oil-silk at *LL*, laying against the plate *r*, covers the hole of the piston, consequently it shuts the communication between the barrel and the cavity of the tube *H*, &c. But if this communication is required to be opened, then the extremity *O* of the lever is pressed down, which will separate the upper part of the piston from the contact of the oil-silk, so as to open the communication as required.

Let us now return to the description of the other parts of the machine, as shewn in fig. 1. The upper extremity *o* of the tube *RS* is made conical, and is fitted by grinding into the strong brass piece of communication *UXl*; the cap *T* serving to tighten it*. The extremity *n* of the opposite piece *np* is likewise fitted by grinding into the part *l*, and is tightened by the cap *m*. Just over the said conical extremities *n* and *o*, and into the same piece of communication *UXl*, are adapted two stop-cocks *Z* and *b*, which are tightened down by the caps

* All the parts of this pump, that are fitted to each other by grinding, as the stop-cocks, the extremity of the tube *RS*, &c. before they are put together, are smeared with a mixture of bees-wax and oil melted together, in order to let them stop the better, and to prevent their wearing by friction.

Y and *i*; but as those stop-cocks must be turned by means of a key adapted to their square tops, and in that case their friction against the caps would unscrew or tighten them; therefore a ring is put round each cap, which ring is prevented from turning by a pin, and is fastened round the cap by means of a screw with a milled head. These rings are seen in fig. 1. of plate II. Each of the stop-cocks is perforated with a hole, which goes from one side to the bottom of it.

The upper part of the piece of communication terminates in a ball *a*, into which the lower and conical extremity *b* of the tube *d* is adapted by grinding, and is fastened by the cap *c*. The tube *d* is foldered to the part *e*, which is made fast to the upper board of the frame of the machine, and to which the plate *ff*, having the rim *gg*, is screwed with a leather between.

The lower part of the piece *np* is screwed with a leather between to the top of the strong brass vessel *qrs*, and is terminated as appears in the figure, for a reason that will be made evident in the sequel. The vessel *qrs* is fastened to the middle shelf of the wooden frame by screws *ss*; and it has a perforation at bottom, which is shut by the screw nut *t*, and serves to let out the oil, which, after working the machine for some time, will be found lodged in the vessel *qrs*.

The tube *Er* is foldered into the piece *D*, and likewise into the vessel mentioned above, wherein it proceeds till very near the top of the vessel, where it opens.

The piston of the pump, with its axis *GG*, is moved upwards and downwards by means of the rock-work, wheel, and handle; which parts being clearly shewn in fig. 1. and 2. of plate II. and also being nothing new, require no farther description.

To the fore-side of the ball *a*, on the strong piece of communication, is adapted by a cross-piece and a screw, the gage which shews the exhaustion of the pump. This gage may be seen in fig. 1. of plate II. It consists of an outward glass tube containing a little quicksilver; and of an inside tube, which, like a barometer, is filled with, and inverted into, the quicksilver of the large tube. The inside tube is supported at top by a spring socket. A small ivory scale, with divisions, encompasses the small tube, and swims upon the surface of the quicksilver in the large tube. By means of this scale the exhaustion of the pump may be begun to be measured, after that the air is rarefied at least thirty times.

To the other side of the ball *a*, *viz.* opposite to the gage, there is a screw-nut, which, by means of a leather, shuts a hole made in the said ball, and serves to open the communication between the receiver and the atmosphere. This nut, besides a milled head, has a square filed on it, to which a key may be applied, in order to open the screw more easily, and by degrees without jerks, which can hardly be avoided when the nut is opened by one's finger applied immediately to it. This nut is seen in plate I.

I shall forbear from any more prolix description of other gages that may be adapted to this pump, as also of other parts necessary for performing experiments with it, these things being very well known at present, and containing nothing new.

Now, as to the working of this pump, a bare inspection of fig. 1. in plate III. will shew, that by the action of the piston, when moved up and down into the barrel, the air will be exhausted from the cavity of the tube RS, of the ball *a*, tube *d*, and of course from the glass receiver that is put upon the plate *ff*; for when the piston, after being let down, is drawn upwards,

the

the under part of the barrel remains without any air; consequently the valve at the bottom of the barrel, having no pressure on one side, will be pushed up by the air in the receiver, which expanding comes through the tube *RS*, and part of it passes into the barrel. Then the piston on being let down, the air passes through the valve of the piston, to the upper part of the barrel, and when afterwards the piston is drawn up, this air is forced through the valve at *E* into the tube *Dr*, from thence into the vessel *qs*, through the channel *pn*, and, lastly, it will be expelled into the atmosphere through the aperture *k*.

As some small quantity of oil is always necessary to be put into the pump, this oil, by the action of the piston, is brought, together with the air, towards the tube *Dr*, and would come out of the hole *k* if the vessel *qs* had not been placed to receive it; and it is for this reason, that the lower part of the piece *pn* is shaped as shewn in the figure, and that the tube *Dr* is made to proceed almost as far as the top of the vessel *qs*; for if the oil was permitted to come out of the aperture *k*, it would be scattered about the instrument and the operator, by the violence of the air coming out of *k*.

As this pump exhausts exactly in the same manner as other pumps do, the lever which opens the valve at the bottom of the barrel is not to be moved, except when such a degree of exhaustion is required as cannot be made by the instrument itself, *viz.* when worked in the ordinary way. In fact, it will be seen by the gage, that when the mercury cannot fall any lower by the usual way of working the pump, it will be instantly depressed by opening the valve at the bottom of the barrel, which evidently shews the great advantage of the improvement. In general, the lever may be begun to be pressed, or, which is the same thing, the valve to be opened, when the

gage shews that the exhaustion of the air is to about 100 times, *viz.* that the quantity of the air remaining within the receiver is about the one-hundredth part of the air that was contained in it before the exhaustion was commenced. Care must be taken to open the valve only whilst the piston is drawing up, and to remove the foot from the lever the moment that the piston is impelled downwards, otherwise the work is usefess.

In the situation in which the pump is shewn by fig. 1. pl. III. it is evident, that as the action of the pump determines the air to move from the tube RS into the barrel and from the barrel up the tube Dr, &c.; it is evident, I say, that if a receiver is placed upon the plate *ff*, the air will be exhausted from it. But if the stop-cocks Z and *b* are so turned as that the side hole of the cock *b*, as well as that of the cock Z, is turned towards X, then, by the action of the pump, the air, instead of being exhausted, is condensed into the receiver properly placed upon the plate *ff*; for now the air coming from the atmosphere through the aperture X goes down the cavity of the tube RS, enters the barrel, and from the barrel is impelled upwards through Dr, through *pn*, through *a*, *b*, *d*, and lastly into the receiver, which in that case must be pressed down, as is usually done in condensing engines. This situation of the stop-cocks, *viz.* when the instrument is to be used as a condenser, is shewn in fig. 2. of plate III. Two letters, E and C, marked upon the square top of each cock, direct the operator how to turn them, whether for exhausting or for condensing.

The conical holes X and *k*, fig. 1. plate III. are made to receive occasionally the extremities of two stop-cocks. Those stop-cocks are fitted to the holes H and *k* by grinding, and a bladder is adapted to each of them. The use of this contrivance is to introduce into the glass receiver some particular sort
of

of elastic fluid, or to receive into a bladder the elastic fluid that is contained in the receiver. Thus, suppose I want to introduce some fixed air into the receiver; first, I exhaust the common air from the receiver, then put the stop-cock of a bladder containing fixed air to the hole X; lastly I open the stop-cock of the bladder, and turn the cocks *bZ*, so that their side-holes may be turned towards X, and by working the pump the fixed air will immediately pass from the bladder into the receiver. If now this same fixed air is required to be introduced into a bladder again, the stop-cocks must be turned with their side holes towards *k*, and a stop-cock with an empty bladder is put to the hole *k*; then, by working the pump, the fixed air will be gradually introduced from the receiver into the bladder.

Having finished the description of this improved air-pump, which, besides its exhausting much better, has various other advantages over any other instrument of the kind; I shall conclude this paper with the succinct account of some experiments made with it, principally to determine how far it can rarefy the air.

Experiments made with the above-described air-pump.

Previous to the narrative of the experiments, it is necessary to mention, that both the plate, and the lower edges of the receivers of this pump, are ground so perfectly true, as not to require any leathers, nor even oil; however, for greater security, some oil is generally poured on the outside of the edge of the receiver, after having exhausted it a little; and it is very seldom, that any visible quantity of this oil passes within the receiver, between its edge and the plate of the pump.

When the hole in the plate of the pump is stopped up by means of a screw and leather, and the instrument is worked for about three or four minutes, the quicksilver in the small tube of the gage falls so low as to be even with the quicksilver in the outside tube, which shews as if the air were entirely exhausted from the inside of the pump; but as it is difficult to judge whether the two surfaces of the mercury in the inside and outside tube are quite on the same level, and even if they were exactly so, there could always be suspected that a little air may be lodged within the gage, notwithstanding that several gages of this sort have been used, in some of which the mercury had been accurately boiled; we must, therefore, have recourse to other gages, in order to determine the exhausting power of this pump with more precision. Accordingly, the pear-gage and long barometer-gage were tried, the effects of which will be related in the sequel.

If, instead of stopping up the hole in the plate of the pump, a glass receiver is laid upon it, and the pump is worked, the gage will also come so low as when no receiver is put upon it; but it must be remarked, that after exhausting and leaving the instrument in that state, when no receiver is upon it, the quicksilver in the gage will be rising for about one hour, so as to ascend one-tenth, or at most one-fifth of an inch above the surface of the quicksilver in the outward tube, and then it remains stationary; whereas if the experiment be repeated when the receiver is upon the plate, the degree of exhaustion remains unaltered, the mercury not rising at all in the small tube. This rising of the quicksilver in the first case seems to be occasioned by some small quantity of elastic fluid, that is yielded by the oil contained between the parts of the machine; for this quantity of elastic fluid can occasion a sensible difference when the exhausted

an improved Air-Pump, &c.

exhausted space within the pump is small, but it becomes quite inconsiderable when the receiver is upon the plate, its quantity bearing a very small proportion to the exhausted space.

It is of great advantage in this pump that very little oil can be lodged in it, because then the elastic fluid yielded by this fluid is in so small a quantity as not to affect the experiments. As for the oil, which by the working of the pump is accumulated into the oil vessel, it cannot interfere with the exhaustion of the pump, since it does not communicate with the cavity of the receiver.

The exhausting power of this pump was next examined with the pear-gage, made and placed under a receiver after the usual manner; and by this it appeared that the pump exhausted so far as to remain within the receiver less than the thousandth part of the air it contained before the exhaustion*. In that case, the quicksilver in a short barometer-gage came to the same level in both tubes, which proves that, by this last mentioned gage in that state, the air is shewn to be rarefied at least one thousand times.

Lastly, a long tube, or what is called a long barometer-gage, was adapted to the pump by means of a bent brass tube. This glass tube went down along the side of the wooden frame, and its lower end was immersed in some quicksilver kept in a proper cistern.

On working the pump, when all the three gages were annexed to it, there appeared, that the quicksilver of the short gage came to the same level in the inside as well as outside tube,

* Whenever the pear-gage was used, care was taken to keep the inside of the receiver, of the pear-gage, and of the pump, as free from moisture as it was possible.

that the quicksilver in the long barometer-gage came as high as it stood at in a real barometer, and that the pear-gage indicated a degree of rarefaction about one thousand. But as it was not known, whether the quicksilver had been boiled into the tube of the barometer, to which the long barometer-gage had been compared, therefore a barometer was accurately made for that purpose. The glass tube had been just drawn at the glass-house. It was perfectly clean; the quicksilver was boiled in the whole length of it, and care was taken that the dimensions of the tube, cistern, and divisions, were alike both in this barometer and in the gage. This done, the pump was tried again, and the quicksilver in the long gage rose within one-twentieth of an inch of the quicksilver in the barometer, or rather less, which shews that the air was rarefied little above 600 times; but at this time the pump was not in proper order for trying such nice experiments. It was leaky, and had not been taken to pieces and cleaned for above six weeks, in which time it had been frequently used, and continually left exposed to the dust of a working-shop: yet it shews, that in these unfavourable circumstances this pump can rarefy the air above 600 times.

Considering all the above-mentioned circumstances and experiments, I think it may be concluded, that this pump, when in good order, can rarefy the air about one thousand times.

I shall, lastly, conclude this paper with a summary account of several electrical experiments, which were made with this pump; reserving to give a more ample and circumstantial account of them for another opportunity.

When the air-pump was in good order, a glass receiver, which had a brass cap cemented to its upper aperture or neck, was laid upon the plate; then the end of the prime conductor of an electric machine was placed within half an inch of the
cap

cap of the receiver; so that when the machine was in action, the electric fluid in the form of sparks went from the conductor to the brass cap, and when the receiver was exhausted, it passed from the cap to the plate of the pump through the receiver, illuminating its whole cavity. The more perfect the vacuum was made, the better conductor of electricity it became, and the electric light was more equably diffused in it; but it became by no means faint, even when the receiver was exhausted to the utmost, though the light changed appearance according as the receiver was more or less exhausted. Those appearances were as follows.

Degrees of rarefaction as shewn by the short gage.	Appearances of the electric light within the receiver.
---	---

Air rarefied 40 times.	Light in large, long, but divided, streams.
70	Fine diffused light, of a white colour.
80	Beautiful diffused light inclining to red or purple, and filling the whole receiver.
100	
400	

When the gage shewed the utmost degree of exhaustion. A diffused light, filled equally every part of the cavity of the jar. It had hardly any reddish hue.

In this state, or even when the air within the receiver was rarefied not above 100 times, if the brass cap of the receiver was made to communicate with the ground by means of good conductors in perfect contact, the light within the receiver occasioned by the electric sparks given by the prime conductor to the cap of the receiver was thereby diminished, but it did

Mr. CAVALLO's Description of an improved Air-Pump.

not intirely vanish ; which shews, that the electric fluid, which proceeded from the conductor to the cap of the receiver in the form of sparks, did not pass to the earth all through the conductor, by which the cap was made to communicate with the ground ; but part of it went at the same time through the vacuum, so that when the pump in this experiment was insulated, sparks could be drawn from the plate of it.

Having repeated the above mentioned experiments with only this variation, *viz.* that the extremity of the prime conductor was put in contact with the cap of the receiver, the appearances of electric light within the receiver were very nearly the same as in the preceding experiments ; but if now the cap of the receiver was made to communicate with the ground, the light within the exhausted receiver vanished intirely, though the electrical machine acted very vigorously.

When a pith-ball electrometer was suspended within the receiver from its brass cap, and some electricity was communicated to the outside of the said cap, its balls diverged very little when the air within the receiver was rarefied about 100 times ; their repulsion was hardly discernible when the air was rarefied about 300 times ; but in a greater degree of rarefaction they did not diverge in the least, and that was the case whether a small or a large quantity of electric fluid was communicated to the cap of the receiver.

June 24, 1783.



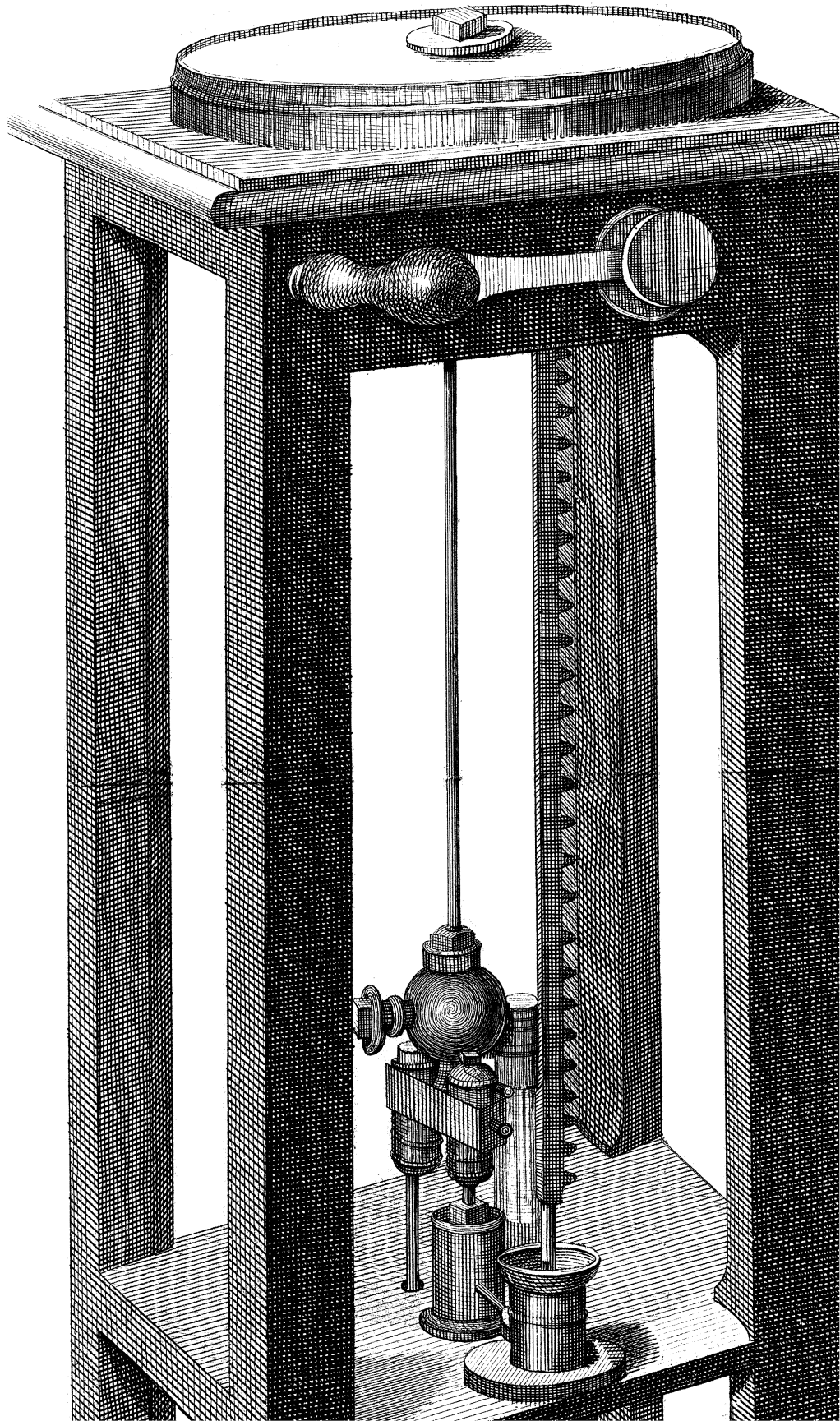

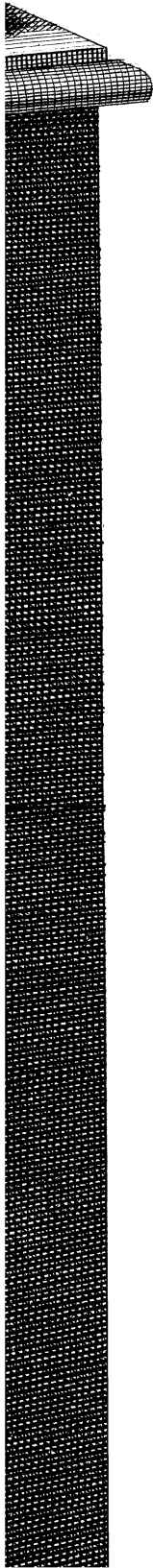

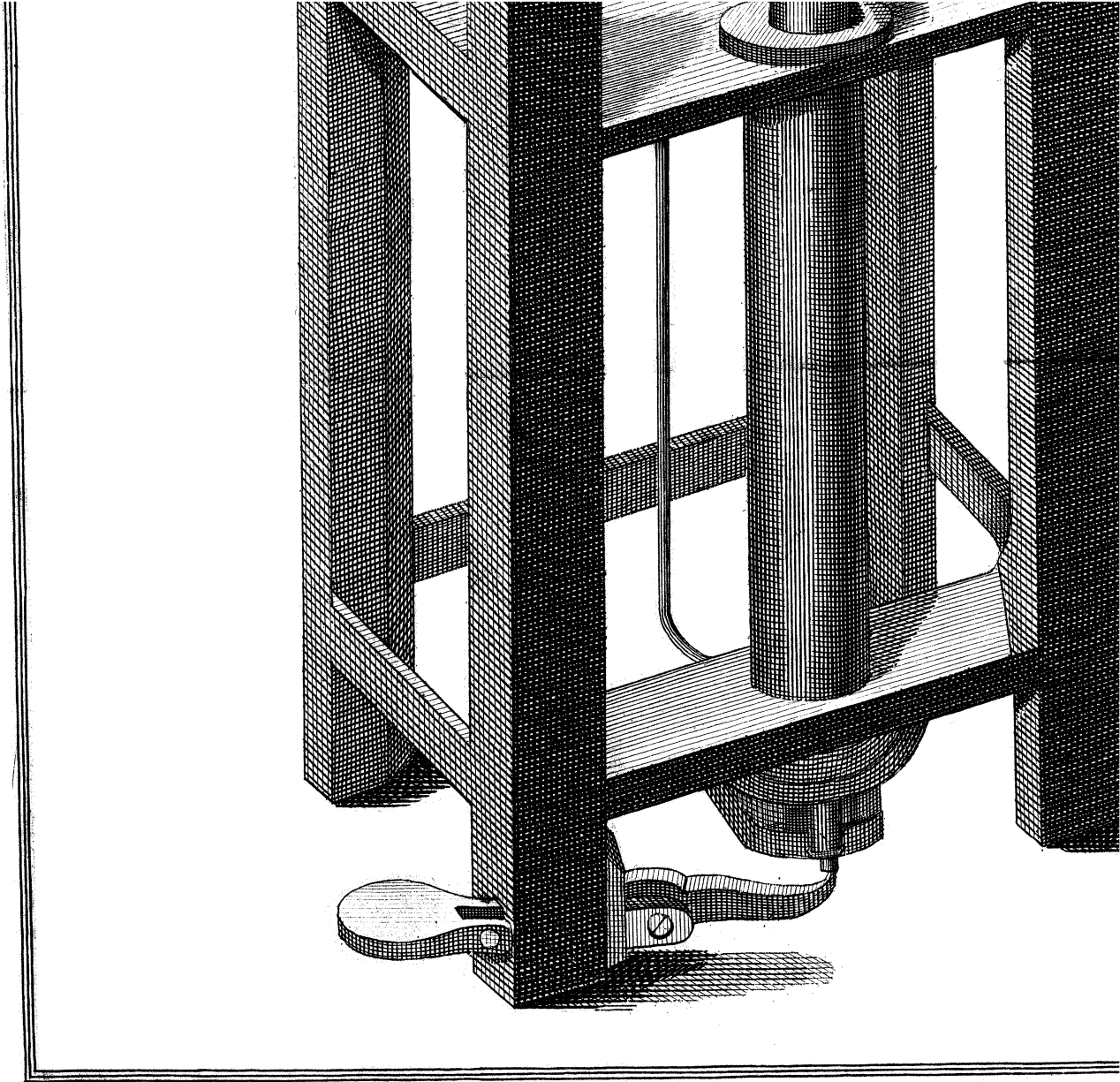

T.H. Hurter del.

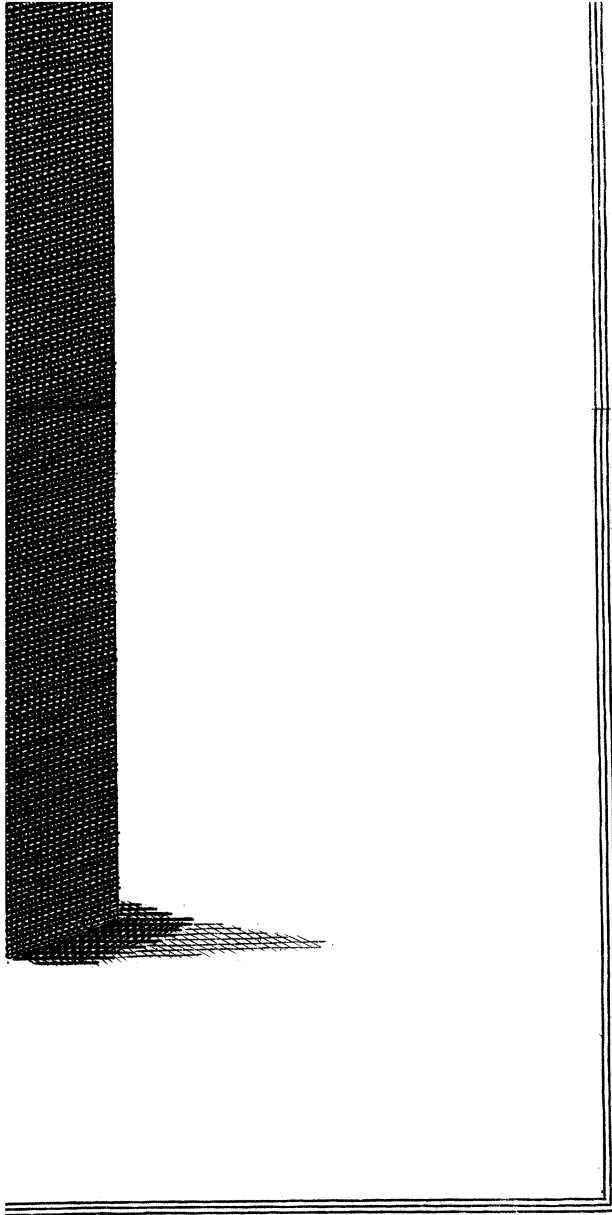

Figure 1.

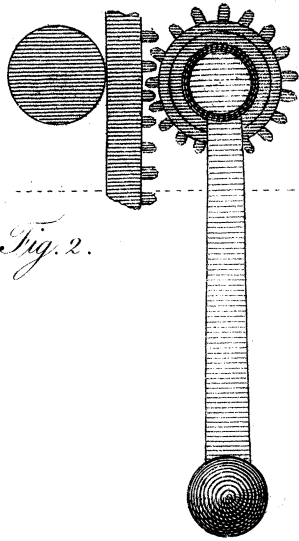

Fig. 2.

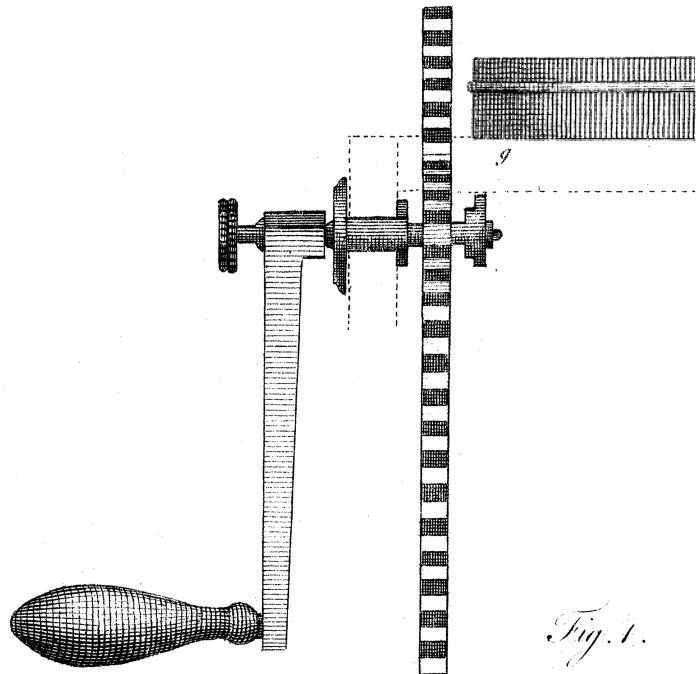

Fig. 1.

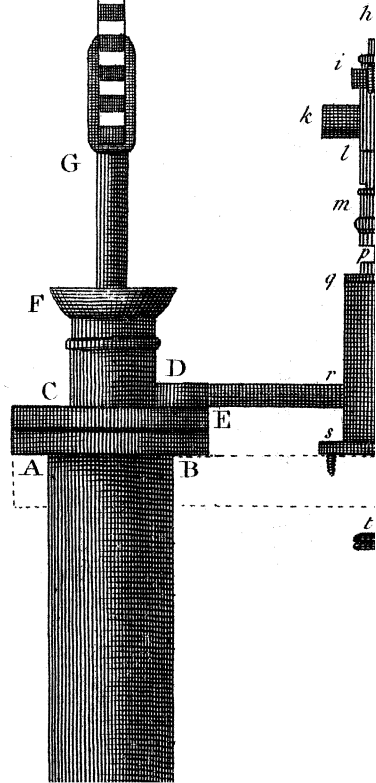
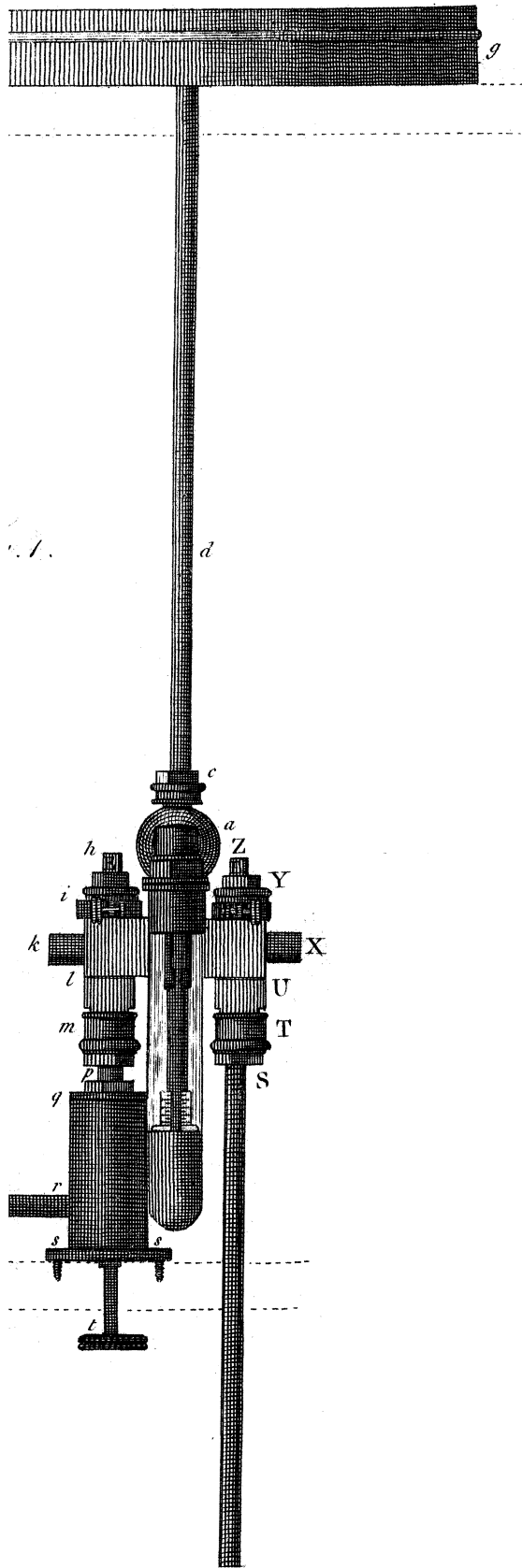

Fig. 3.





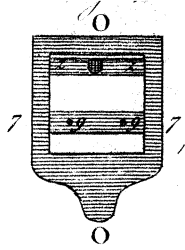
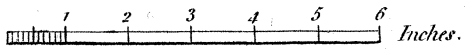
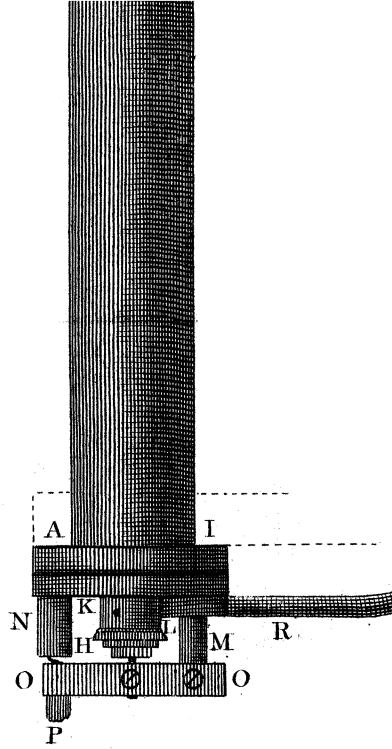
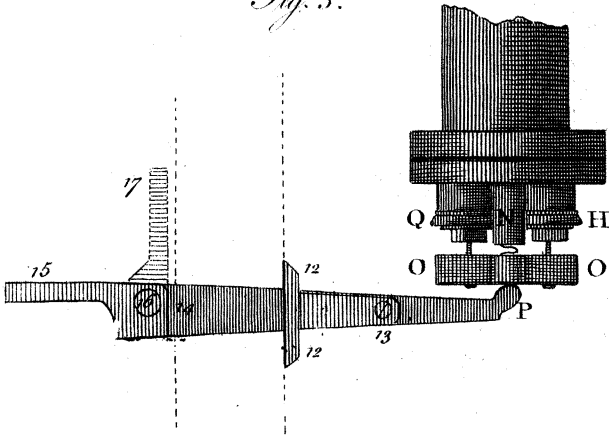
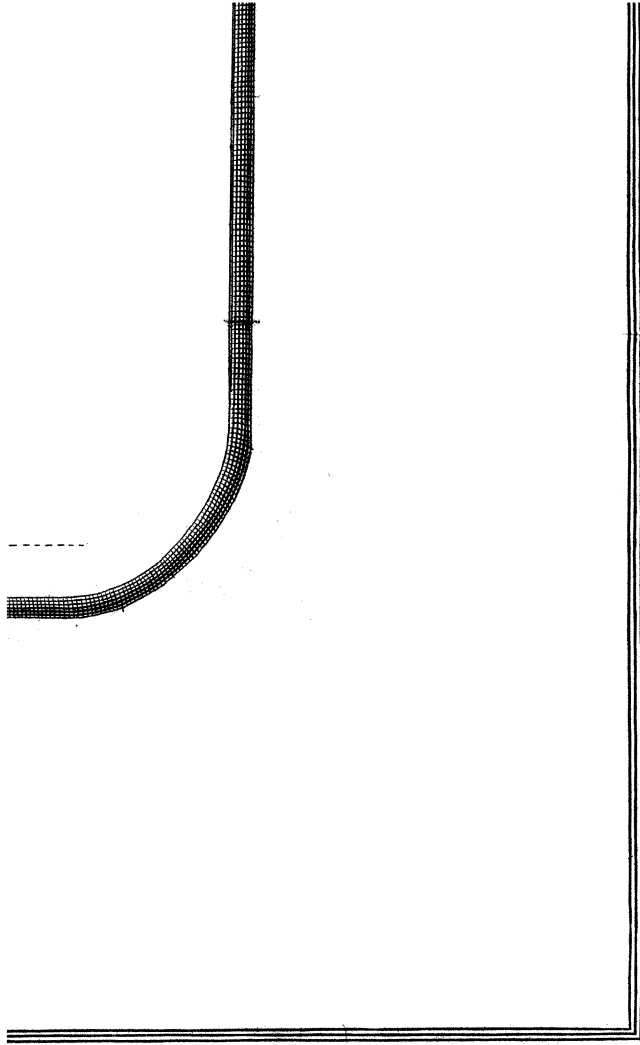

Fig. 3.





Bashe s.

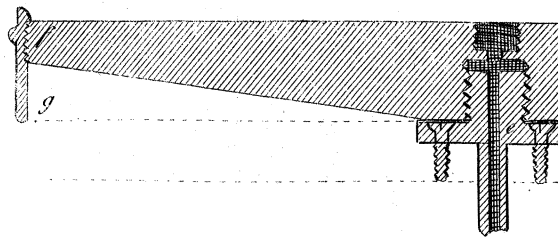

Fig. 2.

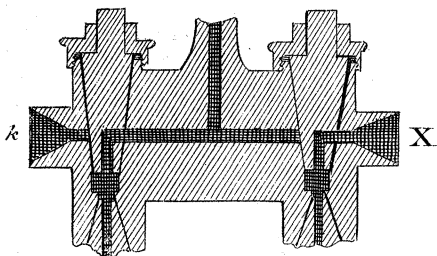

Fig. 1.

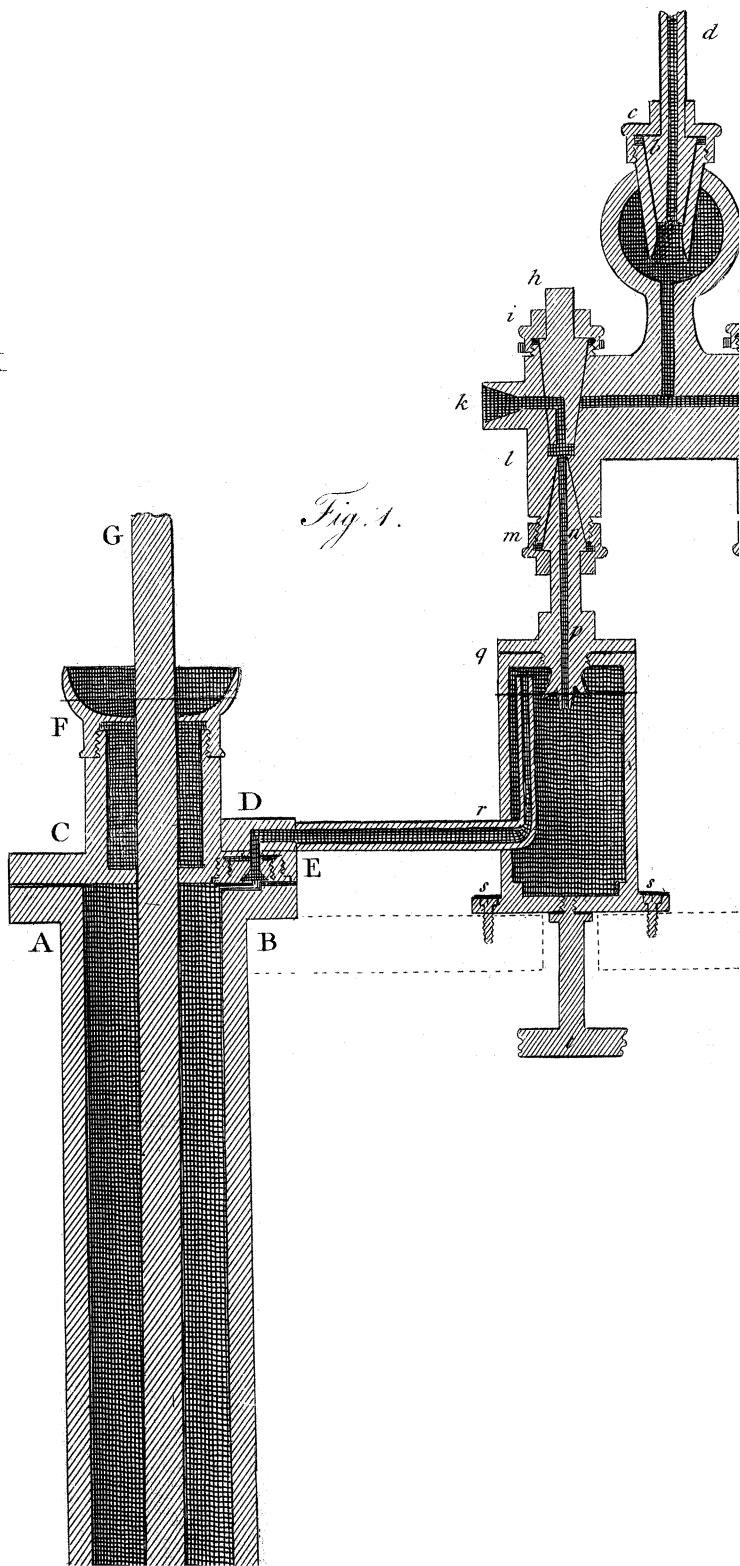
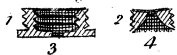
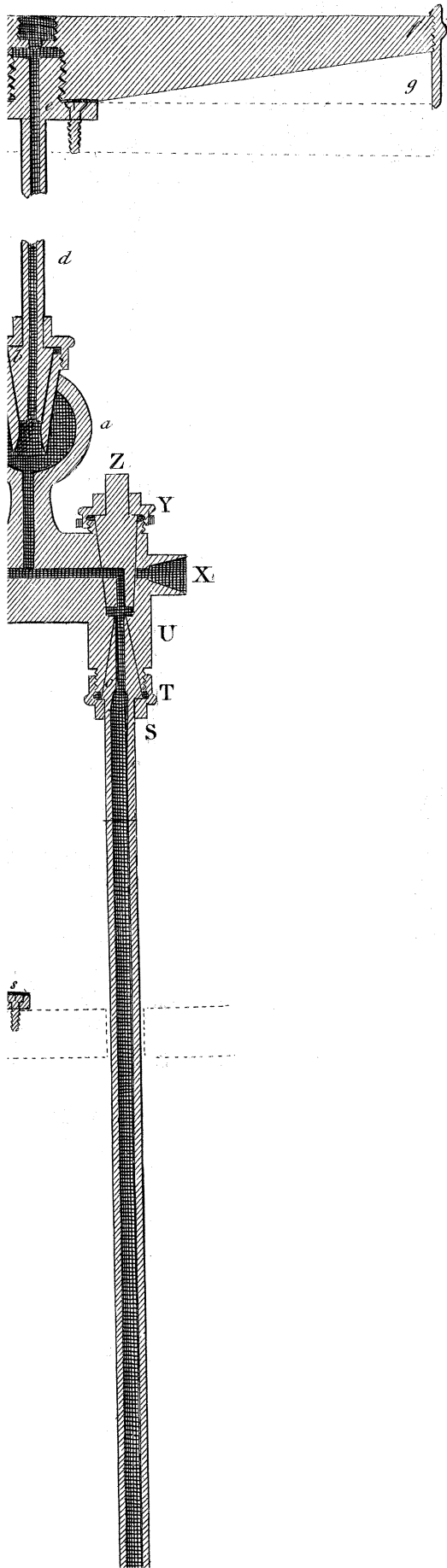

Fig. 3.





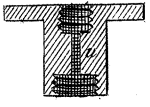

Fig. 4.

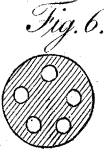

Fig. 6.

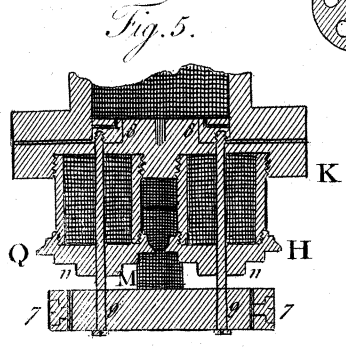
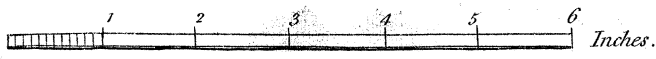
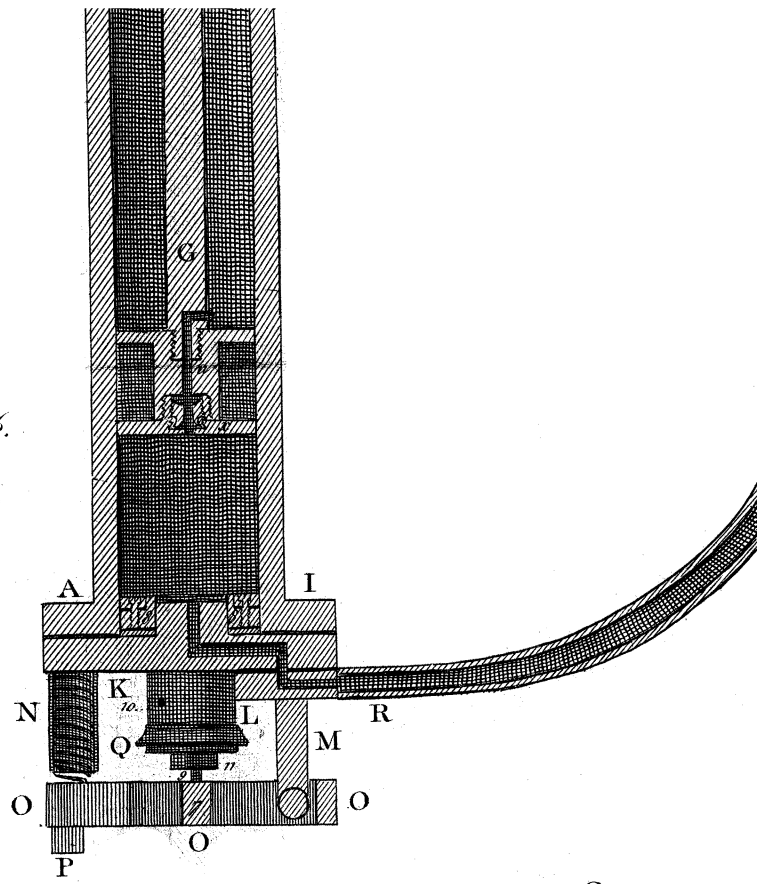
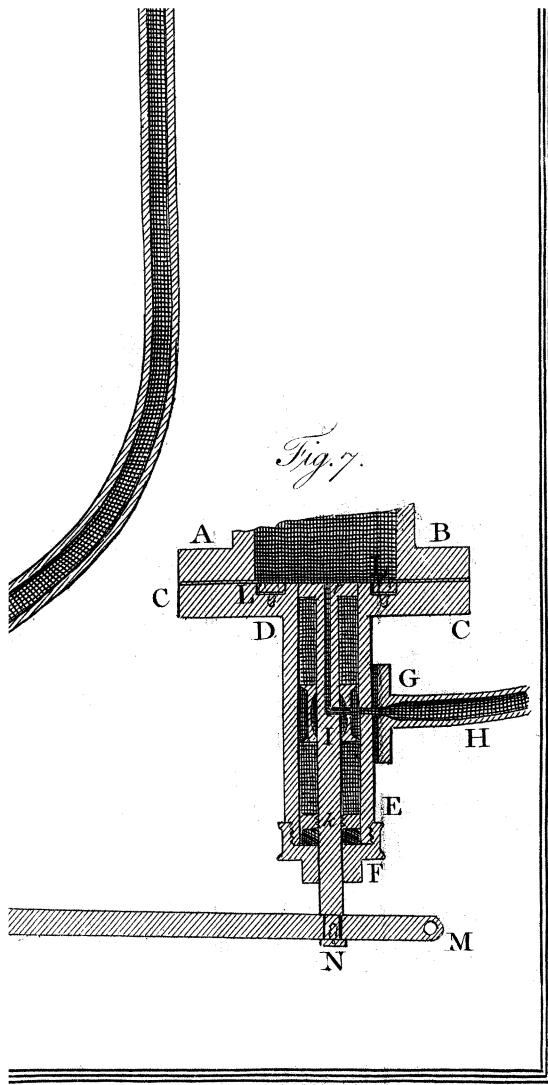
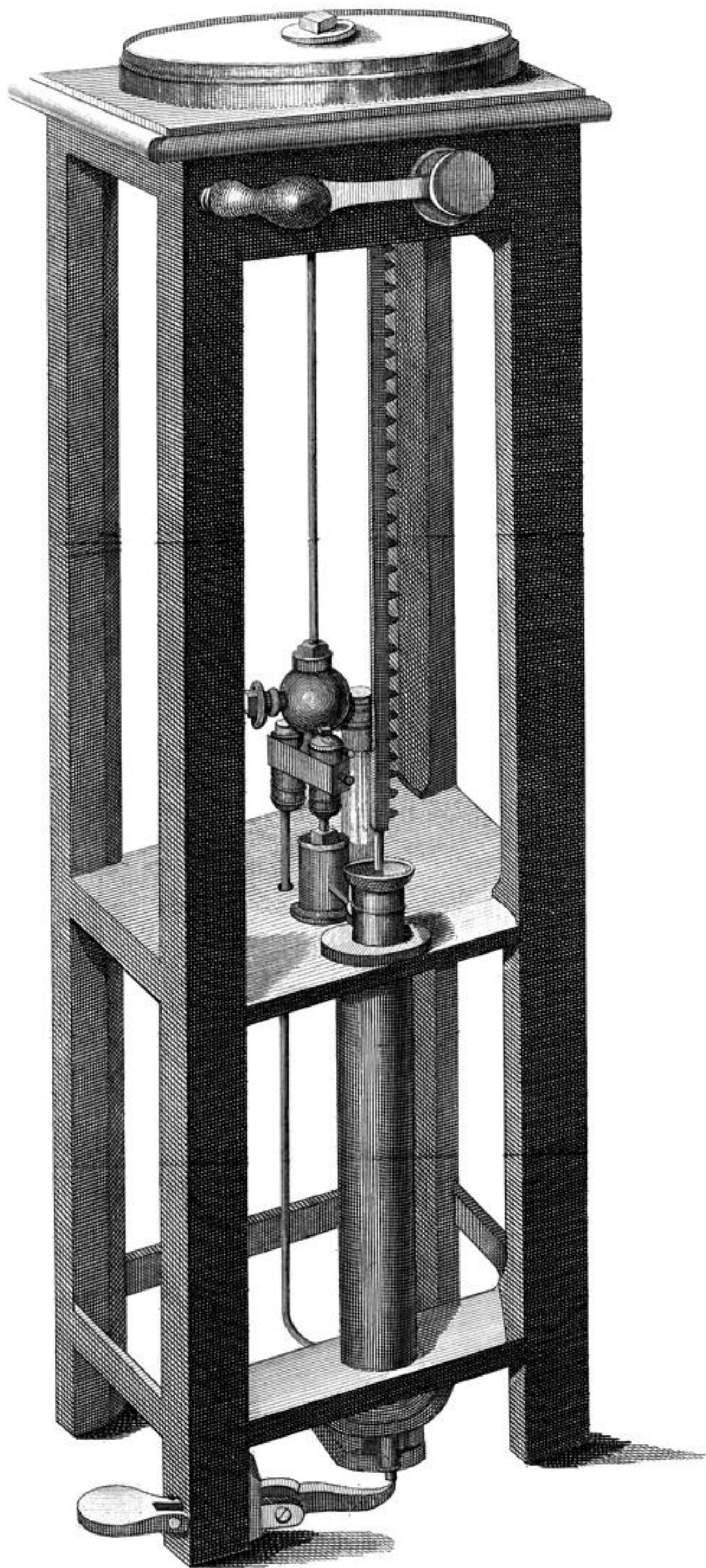

Fig. 5.



Inches.





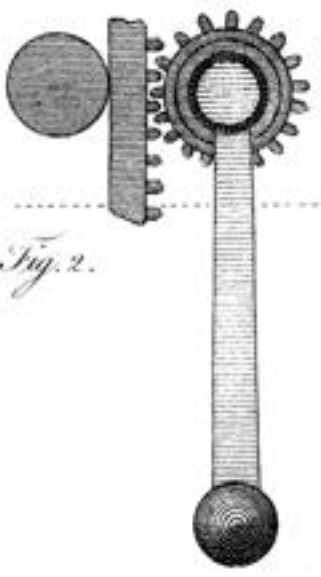

Fig. 2.

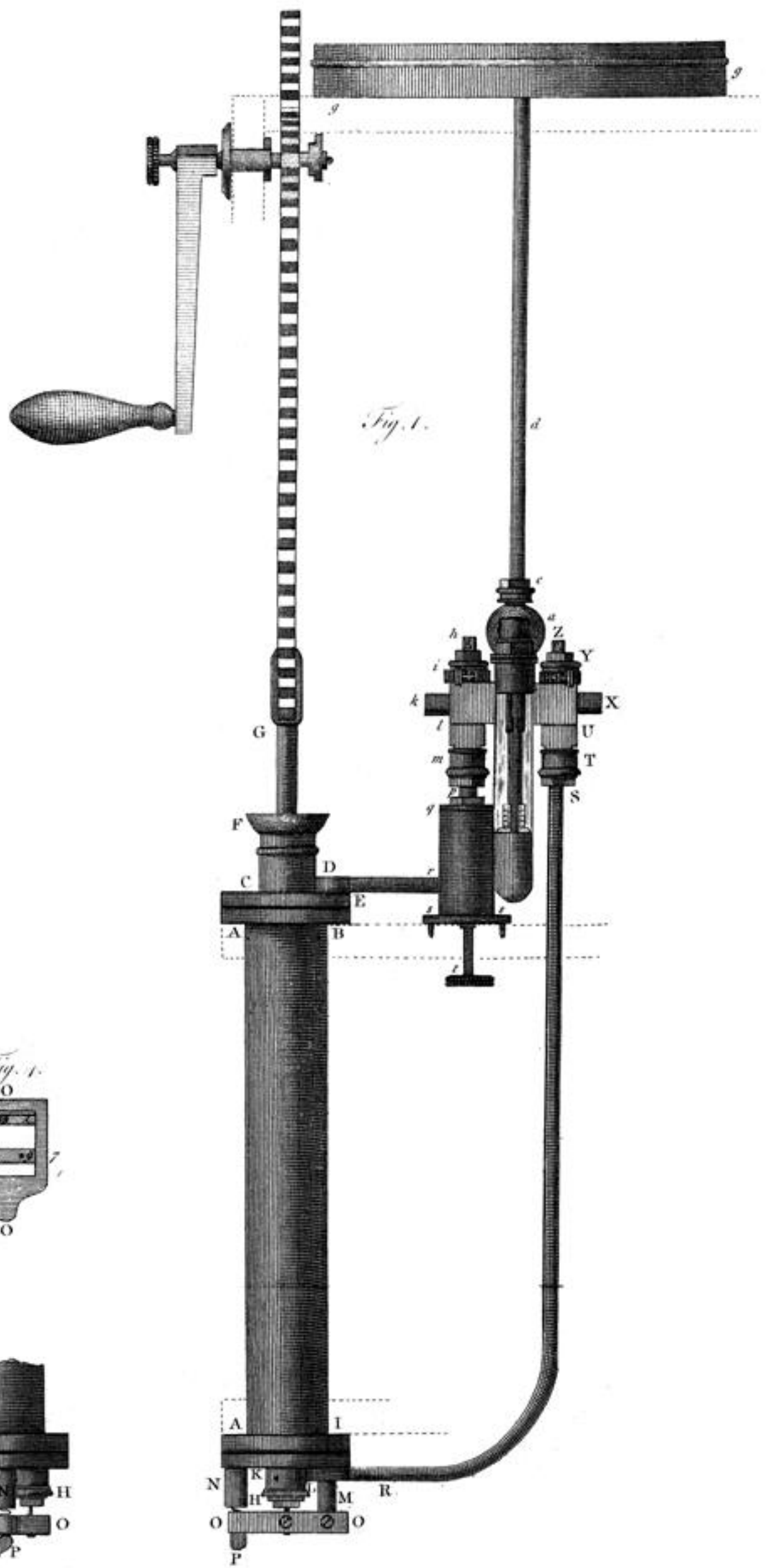

Fig. 1.



Fig. 4.

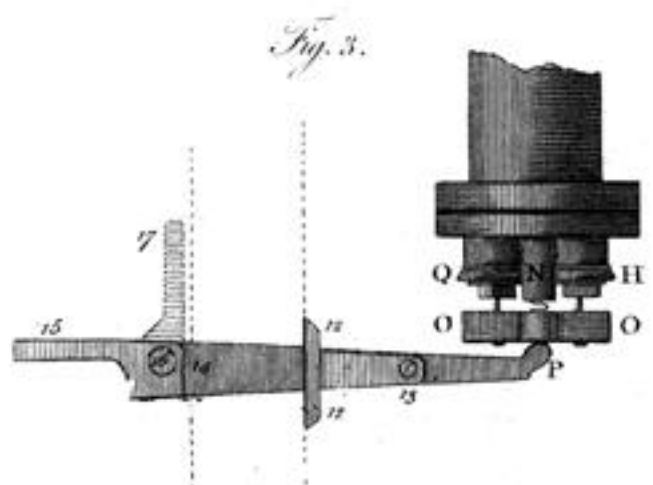
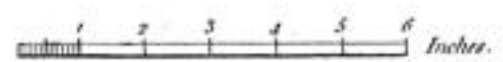

Fig. 3.



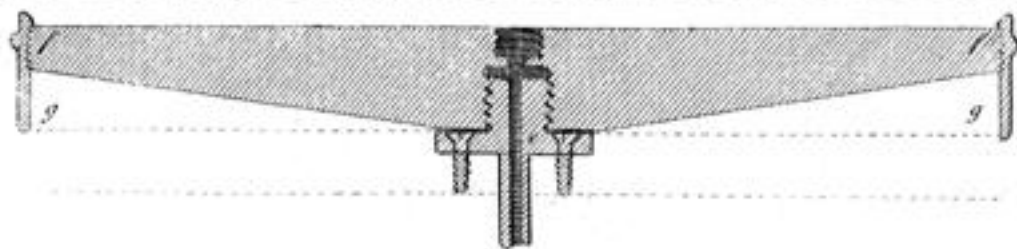

Fig. 2.

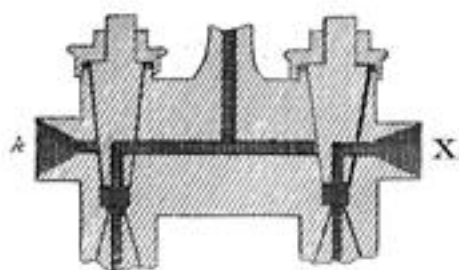

Fig. 3.



Fig. 1.

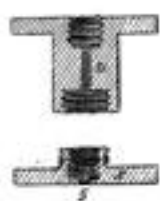
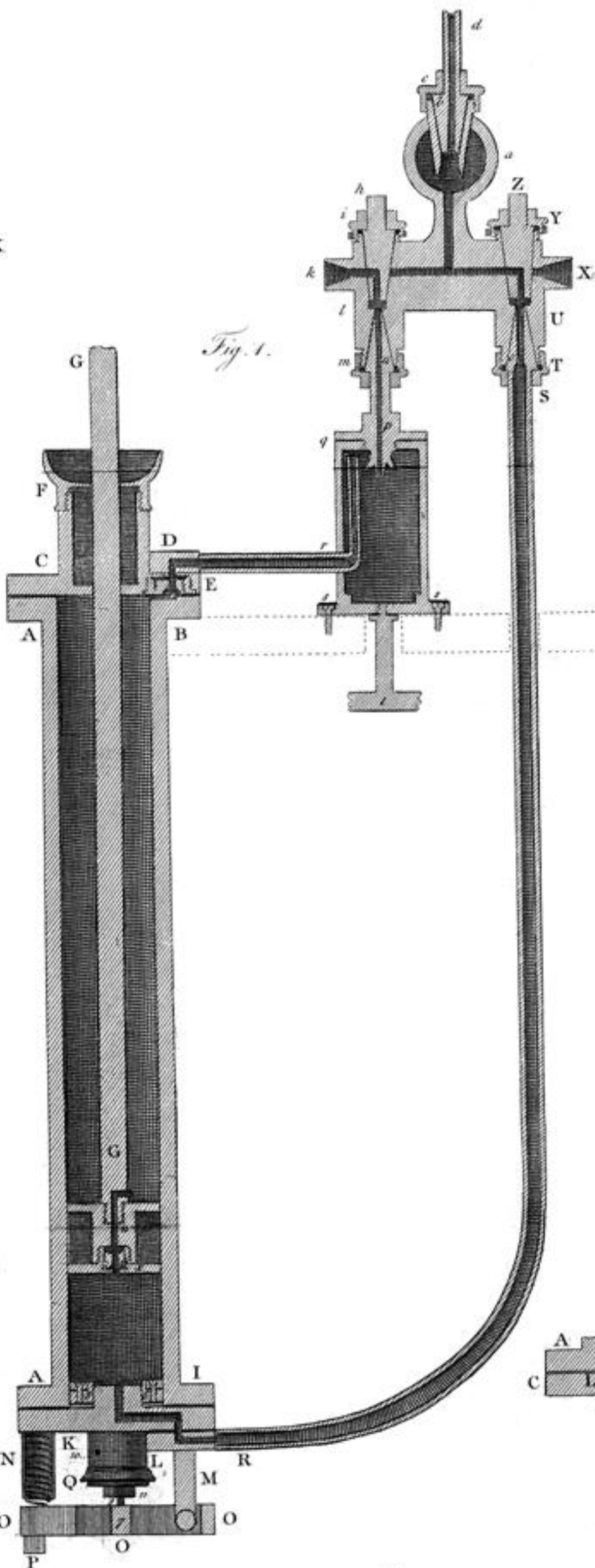

Fig. 4.



Fig. 6.

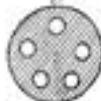

Fig. 5.

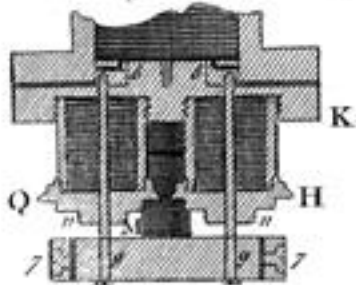

Fig. 7.

